

Part Number	Size	Deg	R	O	H	S Min	B Min	L
24110	1"	11.25°	18	0.3438	3.5	1.875	1.5	3.5
24112	1 1/4"	11.25°	18	0.3438	3.5	2.000	2	3.5
21415	1 1/2"	11.25°	18	0.3438	3.5	2.000	1.375	3.5
24220	2"	11.25°	18	0.3438	3.5	2.000	1.75	3.5
24225	2 1/2"	11.25°	18	0.3438	3.5	3.000	3	3.5
24230	3"	11.25°	18	0.3438	3.5	3.125	2.875	3.5
24235	3 1/2"	11.25°	18	0.3438	3.5	3.250	3.125	3.5
24240	4"	11.25°	18	0.3438	3.5	3.375	3.375	3.5
24250	5"	11.25°	18	0.3438	3.5	3.625	4	3.5
24260	6"	11.25°	18	0.3438	3.5	3.750	5	3.5

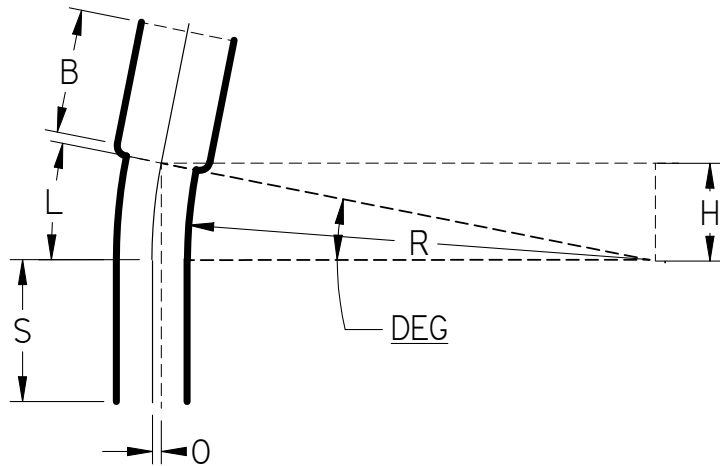

Ⓢ Listed 651
 NEMA TC3
 See NEC Article 352 for Usage



11.25° Elbows Belled End Schedule 40 18" Radius

UNLESS OTHERWISE SPECIFIED
 DIMENSIONS ARE IN INCHES
 ANGLES ±2.0°

	NAME	DATE
DRAWN	K. Mitchell	03/28/13
CHECKED		
ENG APPR		
FILE:	11.25 DEG SCH 40 18 RAD BE.dwg	REV 10