

Part Number	Size	Deg	R	O	H	S Min	B Min	L
24210	1"	11.25°	24	0.461	4.682	1.875	15	4.712
24212	1 1/4"	11.25°	24	0.461	4.682	2.000	2	4.712
24215	1 1/2"	11.25°	24	0.461	4.682	2.000	1.375	4.712
24320	2"	11.25°	24	0.461	4.682	2.000	1.75	4.712
24325	2 1/2"	11.25°	24	0.461	4.682	3.000	3	4.712
24330	3"	11.25°	24	0.461	4.682	3.125	2.875	4.712
24335	3 1/2"	11.25°	24	0.461	4.682	3.250	3.125	4.712
24340	4"	11.25°	24	0.461	4.682	3.375	3.375	4.712
24360	6"	11.25°	24	0.461	4.682	3.750	5	4.712

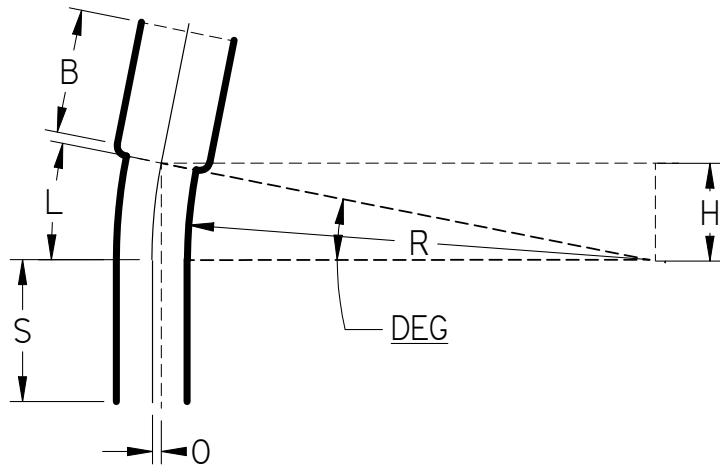

UL Listed 651
 NEMA TC3
 See NEC Article 352 for Usage



11.25° Elbows Belled End Schedule 40 24" Radius

UNLESS OTHERWISE SPECIFIED
 DIMENSIONS ARE IN INCHES
 ANGLES ±2.0°

	NAME	DATE
DRAWN	K. Mitchell	03/28/13
CHECKED		
ENG APPR		
FILE: 11.25 DEG SCH 40 24 RAD BE.dwg REV 10		