

| Part Number | Size   | Deg    | R  | O     | H     | S Min | B Min | L     |
|-------------|--------|--------|----|-------|-------|-------|-------|-------|
| 24310       | 1"     | 11.25° | 30 | 0.576 | 5.853 | 1.875 | 15    | 5.891 |
| 24312       | 1 1/4" | 11.25° | 30 | 0.576 | 5.853 | 2.000 | 2     | 5.891 |
| 24315       | 1 1/2" | 11.25° | 30 | 0.576 | 5.853 | 2.000 | 1.375 | 5.891 |
| 24420       | 2"     | 11.25° | 30 | 0.576 | 5.853 | 2.000 | 1.75  | 5.891 |
| 24425       | 2 1/2" | 11.25° | 30 | 0.576 | 5.853 | 3.000 | 3     | 5.891 |
| 24430       | 3"     | 11.25° | 30 | 0.576 | 5.853 | 3.125 | 2.875 | 5.891 |
| 24435       | 3 1/2" | 11.25° | 30 | 0.576 | 5.853 | 3.250 | 3.125 | 5.891 |
| 22440       | 4"     | 11.25° | 30 | 0.576 | 5.853 | 3.375 | 3.375 | 5.891 |
| 24450       | 5"     | 11.25° | 30 | 0.576 | 5.853 | 3.625 | 4     | 5.891 |

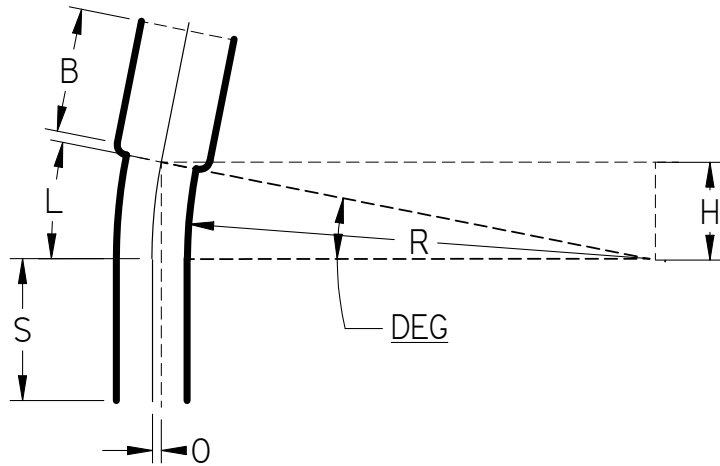

UL Listed 651  
 NEMA TC3  
 See NEC Article 352 for Usage



11.25° Elbows Belled End Schedule 40 30" Radius

UNLESS OTHERWISE SPECIFIED  
 DIMENSIONS ARE IN INCHES  
 ANGLES ±2.0°

|                                      | NAME        | DATE     |
|--------------------------------------|-------------|----------|
| DRAWN                                | K. Mitchell | 03/28/13 |
| CHECKED                              |             |          |
| ENG APPR                             |             |          |
| FILE: 11.25 DEG SCH 40 30 RAD BE.dwg | REV         | 1.0      |