

Part Number	Size	Deg	R	O	H	S Min	L
44410	1"	11.25°	30	0.576	5.853	1.875	5.891
44412	1 1/4"	11.25°	30	0.576	5.853	2.000	5.891
44415	1 1/2"	11.25°	30	0.576	5.853	2.000	5.891
44420	2"	11.25°	30	0.576	5.853	2.000	5.891
44425	2 1/2"	11.25°	30	0.576	5.853	3.000	5.891
44430	3"	11.25°	30	0.576	5.853	3.125	5.891
44435	3 1/2"	11.25°	30	0.576	5.853	3.250	5.891
44440	4"	11.25°	30	0.576	5.853	3.375	5.891
44450	5"	11.25°	30	0.576	5.853	3.625	5.891

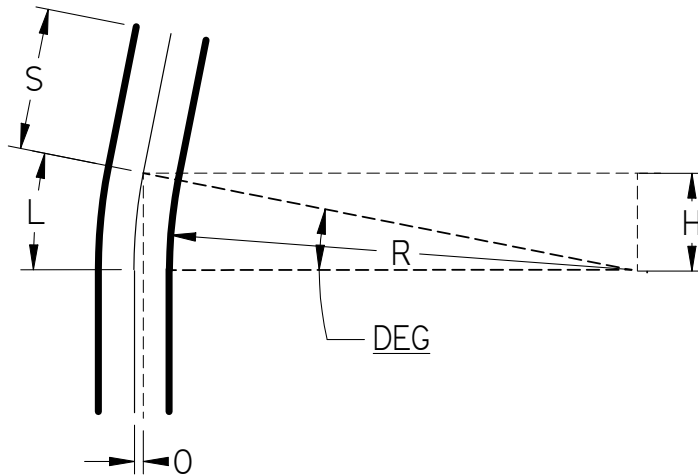

Ⓢ Listed 651
 NEMA TC3
 See NEC Article 352 for Usage

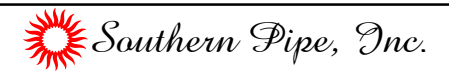

11.25° Elbows Plain End Schedule 40 30" Radius

UNLESS OTHERWISE SPECIFIED
 DIMENSIONS ARE IN INCHES
 ANGLES ±2.0°

	NAME	DATE
DRAWN	K. Mitchell	03/27/13
CHECKED		
ENG APPR		
FILE: 11.25 DEG SCH 40 30 RAD PE.dwg		REV 10