

Part Number	Size	Deg	R	O	H	S Min	B Min	L
24410	1"	11.25°	36	0.6875	7	1.875	1.5	7.0625
24412	1 1/4"	11.25°	36	0.6875	7	2.000	2	7.0625
24415	1 1/2"	11.25°	36	0.6875	7	2.000	1.375	7.0625
24520	2"	11.25°	36	0.6875	7	2.000	1.75	7.0625
24525	2 1/2"	11.25°	36	0.6875	7	3.000	3	7.0625
24530	3"	11.25°	36	0.6875	7	3.125	2.875	7.0625
24535	3 1/2"	11.25°	36	0.6875	7	3.250	3.125	7.0625
24540	4"	11.25°	36	0.6875	7	3.375	3.375	7.0625
24550	5"	11.25°	36	0.6875	7	3.625	4	7.0625
24560	6"	11.25°	36	0.6875	7	3.750	5	7.0625

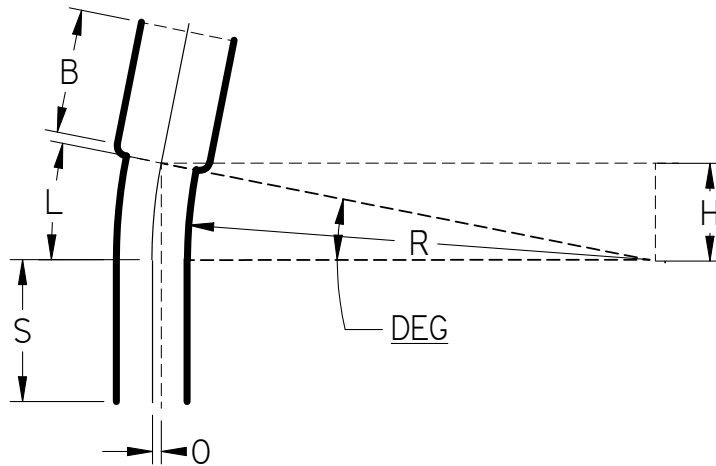

UL Listed 651
 NEMA TC3
 See NEC Article 352 for Usage

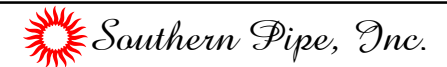

11.25° Elbows Belled End Schedule 40 36" Radius

UNLESS OTHERWISE SPECIFIED
 DIMENSIONS ARE IN INCHES
 ANGLES ±2.0°

	NAME	DATE
DRAWN	K. Mitchell	03/28/13
CHECKED		
ENG APPR		
FILE:	11.25 DEG SCH 40 36 RAD BE.dwg	REV 10