

Part Number	Size	Deg	R	O	H	S Min	B Min	L
24510	1"	11.25°	48	0.9375	9.375	1.875	15	9.4375
24512	1 1/4"	11.25°	48	0.9375	9.375	2.000	2	9.4375
24515	1 1/2"	11.25°	48	0.9375	9.375	2.000	1.375	9.4375
24620	2"	11.25°	48	0.9375	9.375	2.000	1.75	9.4375
24625	2 1/2"	11.25°	48	0.9375	9.375	3.000	3	9.4375
24630	3"	11.25°	48	0.9375	9.375	3.125	2.875	9.4375
24635	3 1/2"	11.25°	48	0.9375	9.375	3.250	3.125	9.4375
24640	4"	11.25°	48	0.9375	9.375	3.375	3.375	9.4375
24650	5"	11.25°	48	0.9375	9.375	3.625	4	9.4375
24660	6"	11.25°	48	0.9375	9.375	3.750	5	9.4375
24680	8"	11.25°	48	0.9375	9.375	6.625	6.75	9.4375

*8" Non UL Listed

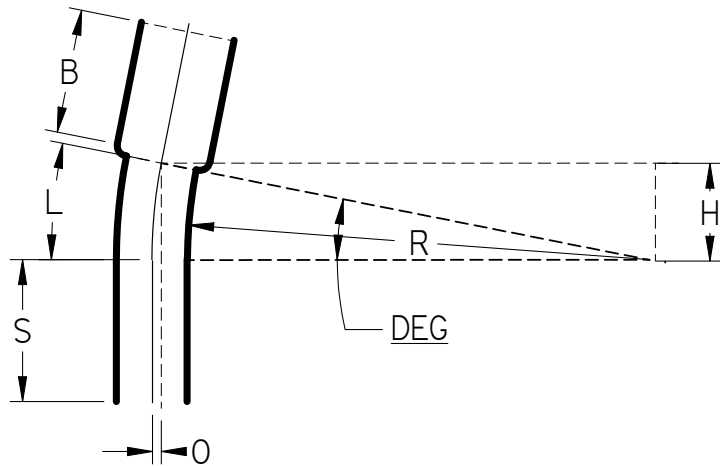

UL Listed 651
 NEMA TC3
 See NEC Article 352 for Usage

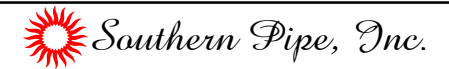

11.25° Elbows Belled End Schedule 40 48" Radius

UNLESS OTHERWISE SPECIFIED
 DIMENSIONS ARE IN INCHES
 ANGLES ±2.0°

	NAME	DATE
DRAWN	K. Mitchell	03/28/13
CHECKED		
ENG APPR		
FILE:	11.25 DEG SCH 40 48 RAD BE.dwg	REV 10