

Part Number	Size	Deg	R	O	H	S Min	B Min	L
29630	3"	11.25°	60	1.125	11.6785	3.125	2.875	11.75
29640	4"	11.25°	60	1.125	11.6785	3.375	3.375	11.75
29650	5"	11.25°	60	1.125	11.6785	3.625	4	11.75
29660	6"	11.25°	60	1.125	11.6785	3.750	5	11.75

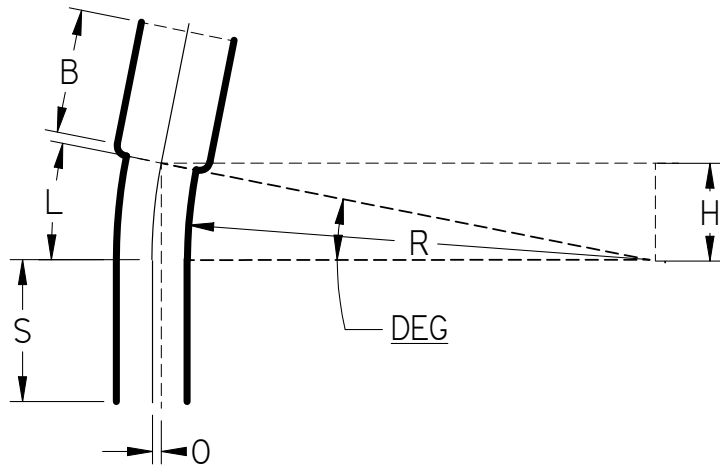

UL Listed 651  
 NEMA TC3  
 See NEC Article 352 for Usage



11.25° Elbows Belled End Schedule 40 60" Radius

UNLESS OTHERWISE SPECIFIED  
 DIMENSIONS ARE IN INCHES  
 ANGLES ±2.0°

	NAME	DATE
DRAWN	K. Mitchell	03/28/13
CHECKED		
ENG APPR		
FILE: 11.25 DEG SCH 40 60 RAD BE.dwg		REV 10