

Part Number	Size	Deg	R	O	H	S Min	L
54210	1"	11.25°	18	0.3438	3.5	1.875	3.5
54212	1 1/4"	11.25°	18	0.3438	3.5	2.000	3.5
54215	1 1/2"	11.25°	18	0.3438	3.5	2.000	3.5
54220	2"	11.25°	18	0.3438	3.5	2.000	3.5
54225	2 1/2"	11.25°	18	0.3438	3.5	3.000	3.5
54230	3"	11.25°	18	0.3438	3.5	3.125	3.5
54235	3 1/2"	11.25°	18	0.3438	3.5	3.250	3.5
54240	4"	11.25°	18	0.3438	3.5	3.375	3.5
54250	5"	11.25°	18	0.3438	3.5	3.625	3.5
54260	6"	11.25°	18	0.3438	3.5	3.750	3.5

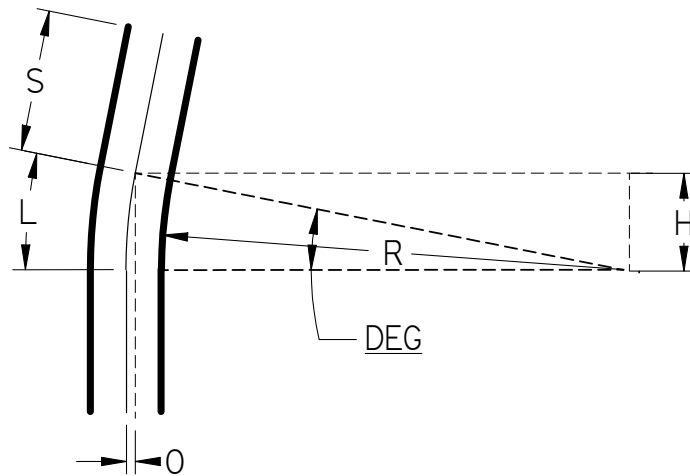

UL Listed 651
 NEMA TC3
 See NEC Article 352 for Usage

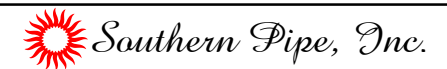

11.25° Elbows Plain End Schedule 40 18" Radius

UNLESS OTHERWISE SPECIFIED
 DIMENSIONS ARE IN INCHES
 ANGLES ±2.0°

	NAME	DATE
DRAWN	K. Mitchell	03/28/13
CHECKED		
ENG APPR		
FILE: 11.25 DEG SCH 40 18 RAD PE.dwg		REV 10