

Part Number	Size	Deg	R	O	H	S Min	L
54610	1"	11.25°	48	0.9375	9.375	1.875	9.4375
54612	1 1/4"	11.25°	48	0.9375	9.375	2.000	9.4375
54615	1 1/2"	11.25°	48	0.9375	9.375	2.000	9.4375
54620	2"	11.25°	48	0.9375	9.375	2.000	9.4375
54625	2 1/2"	11.25°	48	0.9375	9.375	3.000	9.4375
54630	3"	11.25°	48	0.9375	9.375	3.125	9.4375
54635	3 1/2"	11.25°	48	0.9375	9.375	3.250	9.4375
54640	4"	11.25°	48	0.9375	9.375	3.375	9.4375
54650	5"	11.25°	48	0.9375	9.375	3.625	9.4375
54660	6"	11.25°	48	0.9375	9.375	3.750	9.4375

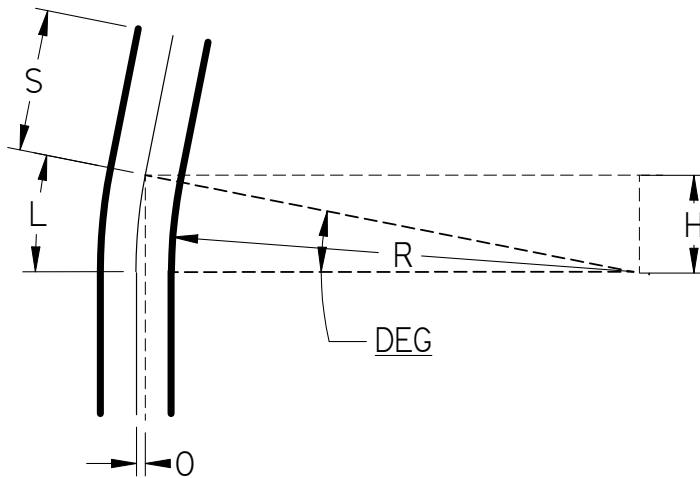

UL Listed 651  
 NEMA TC3  
 See NEC Article 352 for Usage

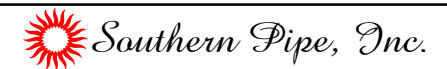

11.25° Elbows Plain End Schedule 40 48" Radius

UNLESS OTHERWISE SPECIFIED  
 DIMENSIONS ARE IN INCHES  
 ANGLES ±2.0°

	NAME	DATE
DRAWN	K. Mitchell	03/28/13
CHECKED		
ENG APPR		
FILE: 11.25 DEG SCH 40 48 RAD PE.dwg		REV 10