

Part Number	Size	Deg	R	O	H	S Min	B Min	L
51708	3/4"	11.25°	4.5	0.086	0.878	1.500	1.5	0.884
51710	1"	11.25°	5.75	0.110	1.122	1.875	1.5	1.129
51712	1 1/4"	11.25°	7.25	0.139	1.414	2.000	2	1.424
51715	1 1/2"	11.25°	8.25	0.159	1.609	2.000	1.375	1.620
51720	2"	11.25°	9.25	0.178	1.805	2.000	1.75	1.816
51725	2 1/2"	11.25°	10.5	0.202	2.048	3.000	3	2.062
51730	3"	11.25°	13	0.250	2.536	3.125	2.875	2.553
51735	3 1/2"	11.25°	15	0.288	2.926	3.250	3.125	2.945
51740	4"	11.25°	16	0.307	3.121	3.375	3.375	3.142
51750	5"	11.25°	24	0.461	4.682	3.625	4	4.712
51760	6"	11.25°	30	0.576	5.853	3.750	5	5.891

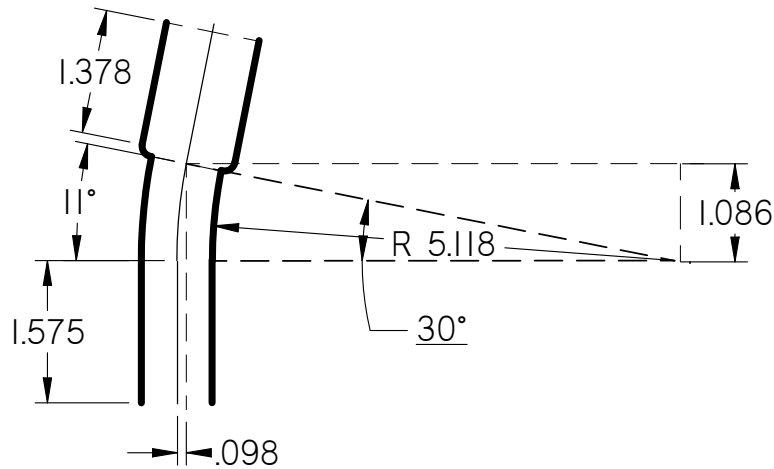

UL Listed 651
 NEMA TC3
 See NEC Article 352 for Usage

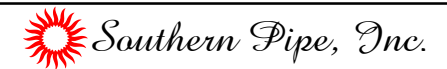

11.25° Elbows Belled End Schedule 80 Standard Radius

UNLESS OTHERWISE SPECIFIED
 DIMENSIONS ARE IN INCHES
 ANGLES ±2.0°

	NAME	DATE
DRAWN	K. Mitchell	04/01/13
CHECKED		
ENG APPR		
FILE: 11.25 DEG SCH 80 STD RAD BELLED END		

REV 1.0