

Part Number	Size	Deg	R	O	H	S Min	L
50408	3/4"	11.25°	4.5	0.086	0.878	1.500	0.884
50410	1"	11.25°	5.75	0.110	1.122	1.875	1.129
50412	1 1/4"	11.25°	7.25	0.139	1.414	2.000	1.424
50415	1 1/2"	11.25°	8.25	0.159	1.609	2.000	1.620
50420	2"	11.25°	9.25	0.178	1.805	2.000	1.816
50425	2 1/2"	11.25°	10.5	0.202	2.048	3.000	2.062
50430	3"	11.25°	13	0.250	2.536	3.125	2.553
50435	3 1/2"	11.25°	15	0.288	2.926	3.250	2.945
50440	4"	11.25°	16	0.307	3.121	3.375	3.142
50450	5"	11.25°	24	0.461	4.682	3.625	4.712
50460	6"	11.25°	30	0.576	5.853	3.750	5.891

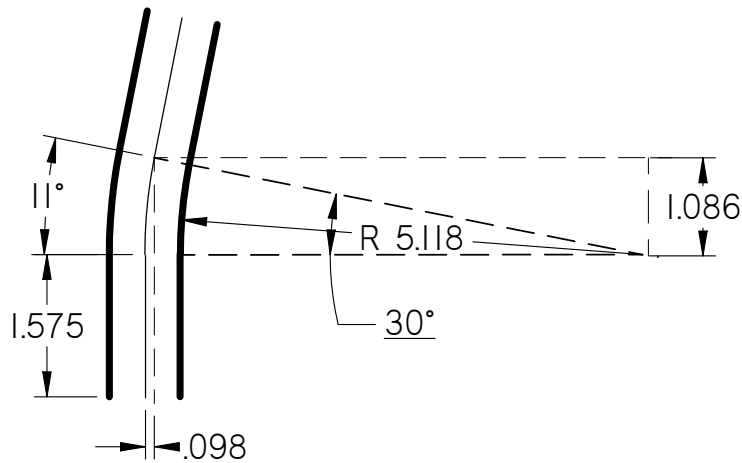

UL Listed 651  
 NEMA TC3  
 See NEC Article 352 for Usage

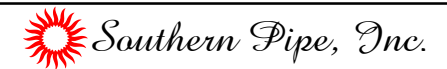

11.25° Elbows Plain End Schedule 80 Standard Radius

UNLESS OTHERWISE SPECIFIED  
 DIMENSIONS ARE IN INCHES  
 ANGLES ±2.0°

	NAME	DATE
DRAWN	K. Mitchell	04/01/13
CHECKED		
ENG APPR		
FILE: 11.25 DEG SCH 80 STD RAD PE.dwg		