

Part Number	Size	Deg	R	O	H	S Min	B Min	L
23710	1"	22.5°	24	1.8125	9.1875	1.875	15	9.4375
23712	1 1/4"	22.5°	24	1.8125	9.1875	2	2	9.4375
23715	1 1/2"	22.5°	24	1.8125	9.1875	2	1.375	9.4375
23820	2"	22.5°	24	1.8125	9.1875	2	1.75	9.4375
23825	2 1/2"	22.5°	24	1.8125	9.1875	3	3	9.4375
23830	3"	22.5°	24	1.8125	9.1875	3.125	2.875	9.4375
23835	3 1/2"	22.5°	24	1.8125	9.1875	3.25	3.125	9.4375
23840	4"	22.5°	24	1.8125	9.1875	3.375	3.375	9.4375

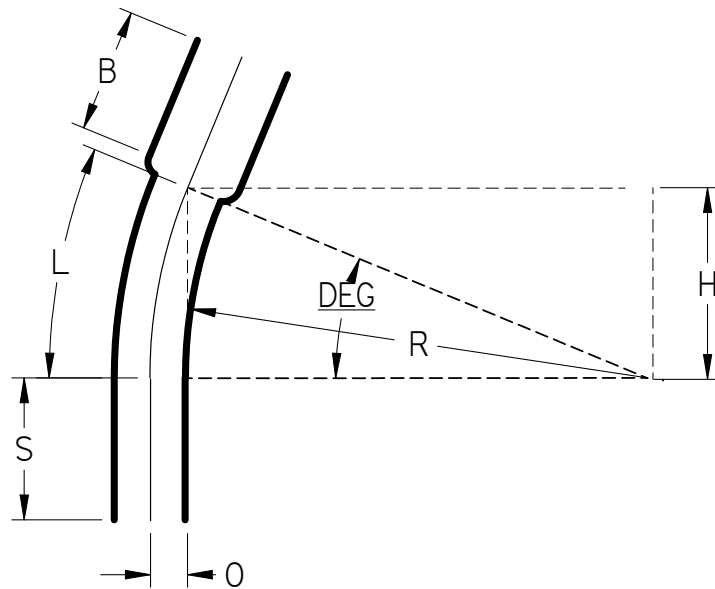

UL Listed 651
 NEMA TC3
 See NEC Article 352 for Usage

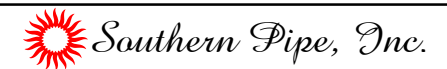

22.5° Elbows Belled End Schedule 40 24" Radius

UNLESS OTHERWISE SPECIFIED
 DIMENSIONS ARE IN INCHES
 ANGLES ±2.0°

	NAME	DATE
DRAWN	K. Mitchell	03/28/13
CHECKED		
ENG APPR		
FILE:	22.5 DEG SCH 40 24 RAD BE.dwg	REV 10