

Part Number	Size	Deg	R	O	H	S Min	B Min	L
23810	1"	22.5°	30	2.25	11.5	1.875	1.5	11.75
23812	1 1/4"	22.5°	30	2.25	11.5	2	2	11.75
23815	1 1/2"	22.5°	30	2.25	11.5	2	1.375	11.75
23920	2"	22.5°	30	2.25	11.5	2	1.75	11.75
23925	2 1/2"	22.5°	30	2.25	11.5	3	3	11.75
23930	3"	22.5°	30	2.25	11.5	3.125	2.875	11.75
23935	3 1/2"	22.5°	30	2.25	11.5	3.25	3.125	11.75
23940	4"	22.5°	30	2.25	11.5	3.375	3.375	11.75
23950	5"	22.5°	30	2.25	11.5	3.625	4	11.75

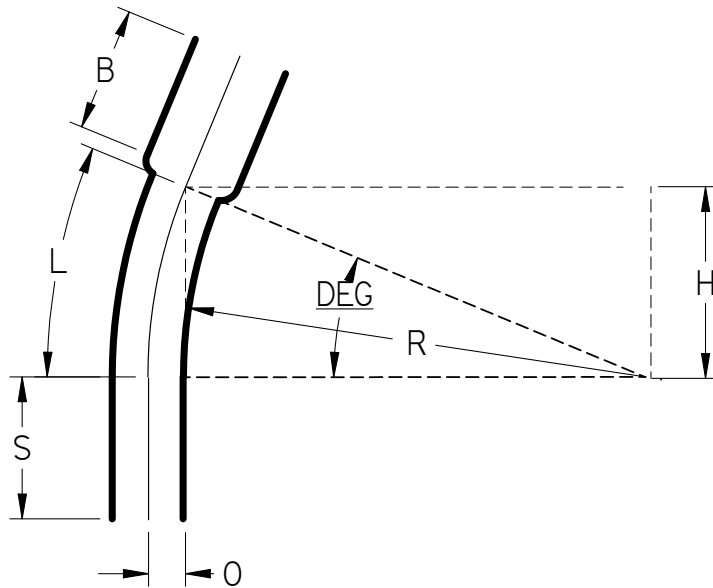

Ⓢ Listed 651
 NEMA TC3
 See NEC Article 352 for Usage

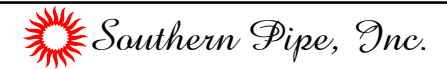

22.5° Elbows Belled End Schedule 40 30" Radius

UNLESS OTHERWISE SPECIFIED
 DIMENSIONS ARE IN INCHES
 ANGLES ±2.0°

	NAME	DATE
DRAWN	K. Mitchell	03/28/13
CHECKED		
ENG APPR		
FILE: 22.5 DEG SCH 40 30 RAD BE.dwg	REV	10