

Part Number	Size	Deg	R	O	H	S Min	B Min	L
24010	1"	22.5°	48	3.625	18.375	1.875	1.5	18.875
24012	1 1/4"	22.5°	48	3.625	18.375	2	2	18.875
24015	1 1/2"	22.5°	48	3.625	18.375	2	1.375	18.875
24120	2"	22.5°	48	3.625	18.375	2	1.75	18.875
24125	2 1/2"	22.5°	48	3.625	18.375	3	3	18.875
24130	3"	22.5°	48	3.625	18.375	3.125	2.875	18.875
24135	3 1/2"	22.5°	48	3.625	18.375	3.25	3.125	18.875
24140	4"	22.5°	48	3.625	18.375	3.375	3.375	18.875
24150	5"	22.5°	48	3.625	18.375	3.625	4	18.875
24160	6"	22.5°	48	3.625	18.375	3.75	5	18.875
24180*	8"	22.5°	48	3.625	18.375	6.625	6.75	18.875

\*8" Non UL Listed

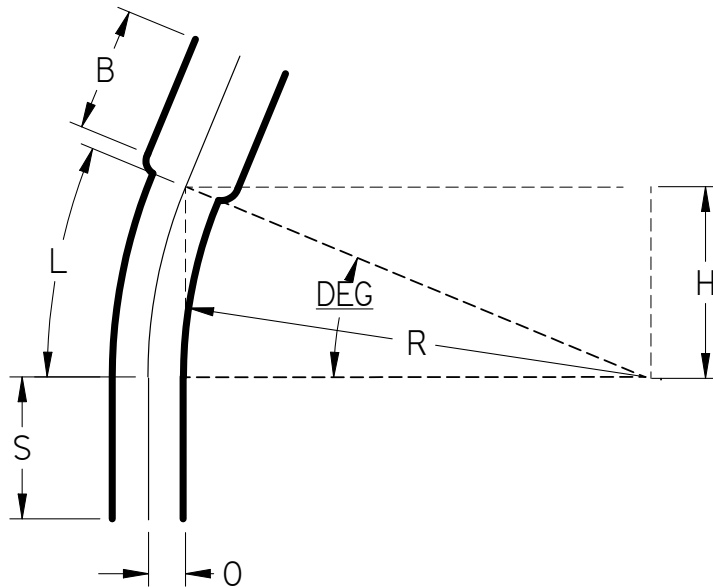

UL Listed 651  
 NEMA TC3  
 See NEC Article 352 for Usage

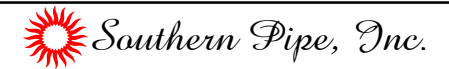

22.5° Elbows Belled End Schedule 40 48" Radius

UNLESS OTHERWISE SPECIFIED  
 DIMENSIONS ARE IN INCHES  
 ANGLES ±2.0°

	NAME	DATE
DRAWN	K. Mitchell	03/28/13
CHECKED		
ENG APPR		
FILE:	22.5 DEG SCH 40 48 RAD BE.dwg	REV 10