

Part Number	Size	Deg	R	O	H	S Min	L
44110	1"	22.5°	48	3.625	18.375	1.875	18.875
44112	1 1/4"	22.5°	48	3.625	18.375	2	18.875
44115	1 1/2"	22.5°	48	3.625	18.375	2	18.875
44120	2"	22.5°	48	3.625	18.375	2	18.875
44125	2 1/2"	22.5°	48	3.625	18.375	3	18.875
44130	3"	22.5°	48	3.625	18.375	3.125	18.875
44135	3 1/2"	22.5°	48	3.625	18.375	3.25	18.875
44140	4"	22.5°	48	3.625	18.375	3.375	18.875
44150	5"	22.5°	48	3.625	18.375	3.625	18.875
44160	6"	22.5°	48	3.625	18.375	3.75	18.875
44180*	8"	22.5°	48	3.625	18.375	6.625	18.875

*8" Non UL Listed

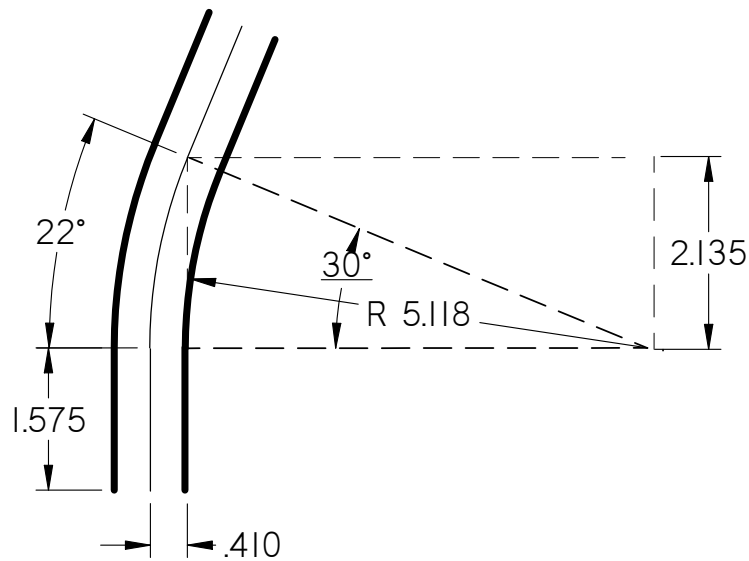

UL Listed 651
 NEMA TC3
 See NEC Article 352 for Usage

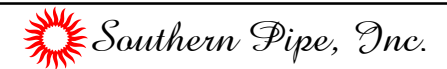

22.5° Elbows Plain End Schedule 40 48" Radius

UNLESS OTHERWISE SPECIFIED
 DIMENSIONS ARE IN INCHES
 ANGLES ±2.0°

	NAME	DATE
DRAWN	K. Mitchell	04/01/13
CHECKED		
ENG APPR		
FILE: 22.5 DEG SCH 40 48 RAD PE.dwg REV 10		