

Part Number	Size	Deg	R	O	H	S Min	B Min	L
21905	1/2"	22.5°	4	0.304	1.531	1.5	1.5	1.571
21908	3/4"	22.5°	4.5	0.343	1.722	1.5	1.5	1.767
21910	1"	22.5°	5.75	0.438	2.200	1.875	1.5	2.258
21912	1 1/4"	22.5°	7.25	0.552	2.774	2	2	2.847
21915	1 1/2"	22.5°	8.25	0.928	3.157	2	1.375	3.240
21920	2"	22.5°	9.25	0.704	3.540	2	1.75	3.632
21925	2 1/2"	22.5°	10.5	0.799	4.018	3	3	4.123
21930	3"	22.5°	13	0.990	4.975	3.125	2.875	5.105
21935	3 1/2"	22.5°	15	1.142	5.740	3.25	3.125	5.891
21940	4"	22.5°	16	1.218	6.123	3.375	3.375	6.283
21950	5"	22.5°	24	1.827	9.184	3.625	4	9.425
21960	6"	22.5°	30	2.284	11.481	3.75	5	11.781

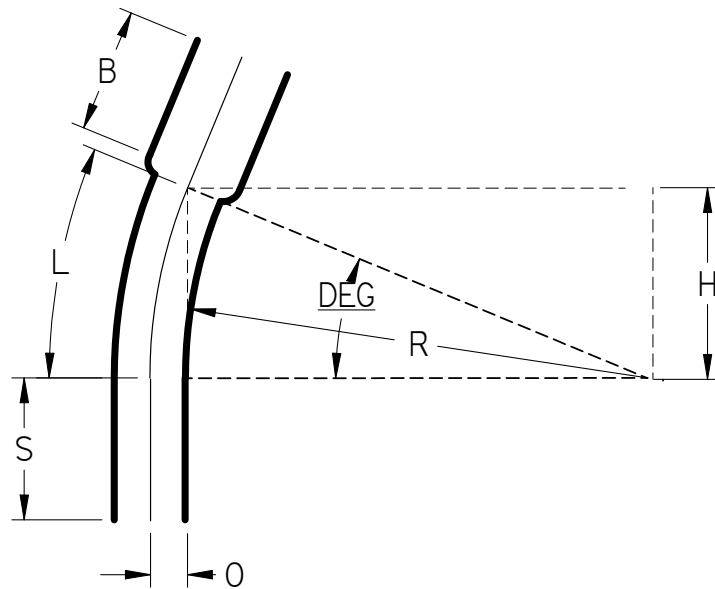

UL Listed 651  
 NEMA TC3  
 See NEC Article 352 for Usage

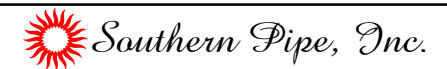

22.5° Elbows Belled End Schedule 40 Standard Radius

UNLESS OTHERWISE SPECIFIED  
 DIMENSIONS ARE IN INCHES  
 ANGLES ±2.0°

	NAME	DATE
DRAWN	K. Mitchell	03/27/13
CHECKED		
ENG APPR		
FILE: 22.5 DEG SCH 40 STD RAD BEL.dwg REV 10		