

Part Number	Size	Deg	R	O	H	S Min	L
54110	1"	22.5°	48	3.625	18.375	1.875	18.875
54112	1 1/4"	22.5°	48	3.625	18.375	2	18.875
54115	1 1/2"	22.5°	48	3.625	18.375	2	18.875
54120	2"	22.5°	48	3.625	18.375	2	18.875
54125	2 1/2"	22.5°	48	3.625	18.375	3	18.875
54130	3"	22.5°	48	3.625	18.375	3.125	18.875
54135	3 1/2"	22.5°	48	3.625	18.375	3.25	18.875
54140	4"	22.5°	48	3.625	18.375	3.375	18.875
54150	5"	22.5°	48	3.625	18.375	3.625	18.875
54160	6"	22.5°	48	3.625	18.375	3.75	18.875

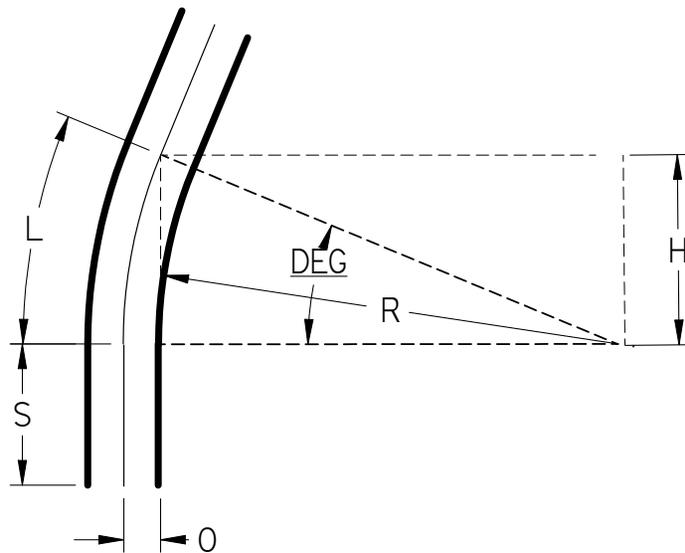

UL Listed 651
 NEMA TC3
 See NEC Article 352 for Usage



22.5° Elbows Plain End Schedule 80 48" Radius

UNLESS OTHERWISE SPECIFIED
 DIMENSIONS ARE IN INCHES
 ANGLES ±2.0°

	NAME	DATE
DRAWN	K. Mitchell	03/28/13
CHECKED		
ENG APPR		
FILE: 22.5 DEG SCH 80 48 RAD PE.dwg		REV 10