

Part Number	Size	Deg	R	O	H	S Min	B Min	L
51805	1/2"	22.5°	4	0.304	1.531	1.5	1.5	1.571
51808	3/4"	22.5°	4.5	0.343	1.722	1.5	1.5	1.767
51810	1"	22.5°	5.75	0.438	2.200	1.875	1.5	2.258
51812	1 1/4"	22.5°	7.25	0.552	2.774	2	2	2.847
51815	1 1/2"	22.5°	8.25	0.928	3.157	2	1.375	3.240
51820	2"	22.5°	9.25	0.704	3.540	2	1.75	3.632
51825	2 1/2"	22.5°	10.5	0.799	4.018	3	3	4.123
51830	3"	22.5°	13	0.990	4.975	3.125	2.875	5.105
51835	3 1/2"	22.5°	15	1.142	5.740	3.25	3.125	5.891
51840	4"	22.5°	16	1.218	6.123	3.375	3.375	6.283
51850	5"	22.5°	24	1.827	9.184	3.625	4	9.425
51860	6"	22.5°	30	2.284	11.481	3.75	5	11.781

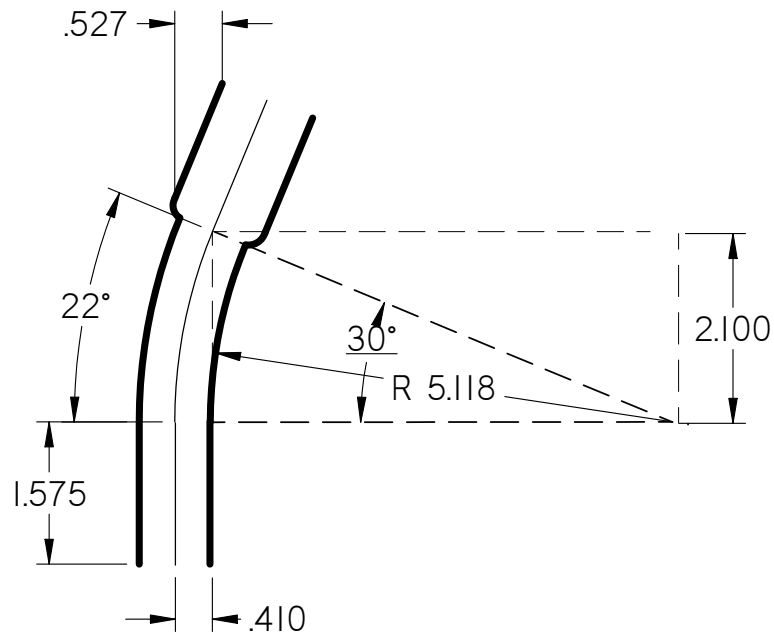

UL Listed 651
 NEMA TC3
 See NEC Article 352 for Usage

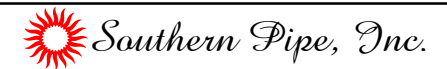

22.5° Elbows Belled End Schedule 80 Standard Radius

UNLESS OTHERWISE SPECIFIED
 DIMENSIONS ARE IN INCHES
 ANGLES ±2.0°

	NAME	DATE
DRAWN	K. Mitchell	04/01/13
CHECKED		
ENG APPR		
FILE: 22.5 DEG SCH 80 STD RAD BE.dwg REV 10		