

Part Number	Size	Deg	R	O	H	S Min	L
50505	1/2"	22.5°	4	0.304	1.531	15	1.571
50508	3/4"	22.5°	4.5	0.343	1.722	15	1.767
50510	1"	22.5°	5.75	0.438	2.200	18.75	2.258
50512	1 1/4"	22.5°	7.25	0.552	2.774	2	2.847
50515	1 1/2"	22.5°	8.25	0.928	3.157	2	3.240
50520	2"	22.5°	9.25	0.704	3.540	2	3.632
50525	2 1/2"	22.5°	10.5	0.799	4.018	3	4.123
50530	3"	22.5°	13	0.990	4.975	3.125	5.105
50535	3 1/2"	22.5°	15	1.142	5.740	3.25	5.891
50540	4"	22.5°	16	1.218	6.123	3.375	6.283
50550	5"	22.5°	24	1.827	9.184	3.625	9.425
50560	6"	22.5°	30	2.284	11.481	3.75	11.781

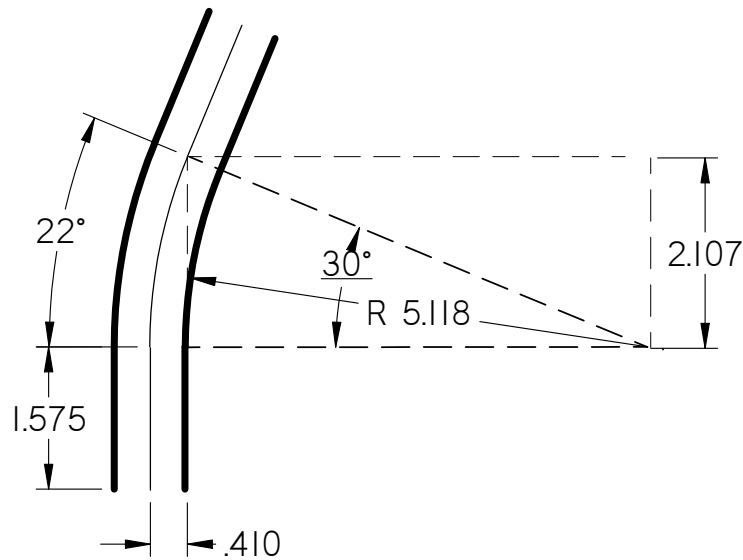

UL Listed 651  
 NEMA TC3  
 See NEC Article 352 for Usage

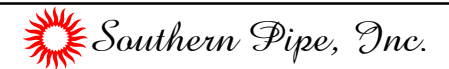

22.5° Elbows Plain End Schedule 80 Standard Radius

UNLESS OTHERWISE SPECIFIED  
 DIMENSIONS ARE IN INCHES  
 ANGLES ±2.0°

	NAME	DATE
DRAWN	K. Mitchell	04/01/13
CHECKED		
ENG APPR		
FILE: 22.5 DEG SCH 80 STD RAD PE.dwg REV 10		