

Part Number	Size	Deg	R	O	H	S Min	B Min	L
23510	1"	30°	48	6.4375	24	1.875	1.5	25.125
23512	1 1/4"	30°	48	6.4375	24	2	2	25.125
23515	1 1/2"	30°	48	6.4375	24	2	1.375	25.125
23620	2"	30°	48	6.4375	24	2	1.75	25.125
23625	2 1/2"	30°	48	6.4375	24	3	3	25.125
23630	3"	30°	48	6.4375	24	3.125	2.875	25.125
23635	3 1/2"	30°	48	6.4375	24	3.25	3.125	25.125
23640	4"	30°	48	6.4375	24	3.375	3.375	25.125
23650	5"	30°	48	6.4375	24	3.625	4	25.125
23660	6"	30°	48	6.4375	24	3.75	5	25.125
23680*	8"	30°	48	6.4375	24	6.625	6.75	25.125

\*8" Non UL Listed

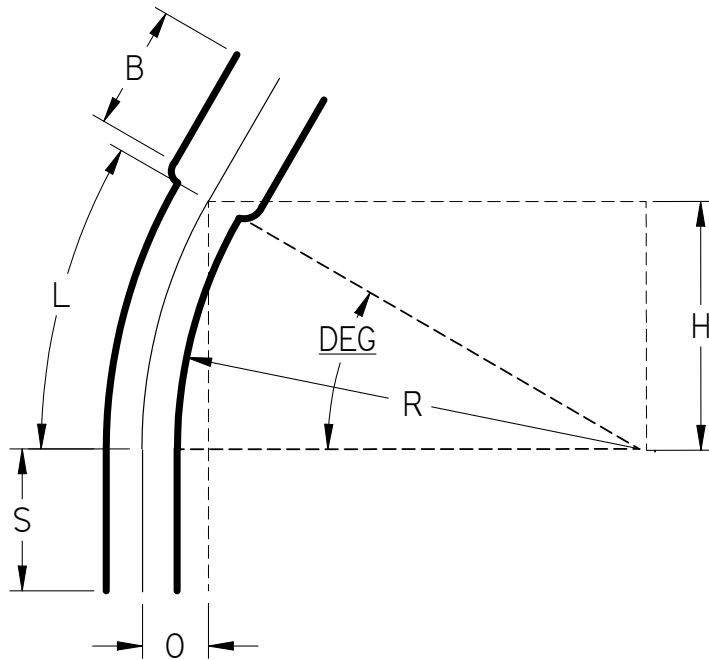

UL Listed 651  
 NEMA TC3  
 See NEC Article 352 for Usage

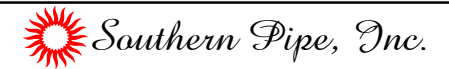

30° Elbows Belled End Schedule 40 48" Radius

UNLESS OTHERWISE SPECIFIED  
 DIMENSIONS ARE IN INCHES  
 ANGLES ±2.0°

	NAME	DATE
DRAWN	K. Mitchell	03/28/13
CHECKED		
ENG APPR		
FILE: 30 DEG SCH 40 48 RAD BE.dft	REV	10