

Part Number	Size	Deg	R	O	H	S Min	L
43610	1"	30°	36	6.4375	24	1.875	25.125
43612	1 1/4"	30°	7.25	6.4375	24	2	25.125
43615	1 1/2"	30°	8.25	6.4375	24	2	25.125
43620	2"	30°	9.25	6.4375	24	2	25.125
43625	2 1/2"	30°	10.5	6.4375	24	3	25.125
43630	3"	30°	13	6.4375	24	3.125	25.125
43635	3 1/2"	30°	15	6.4375	24	3.25	25.125
43640	4"	30°	16	6.4375	24	3.375	25.125
43650	5"	30°	24	6.4375	24	3.625	25.125
43660	6"	30°	30	6.4375	24	3.75	25.125
43680*	8"	30°	30	6.4375	24	6.625	25.125

\*8" Non UL Listed

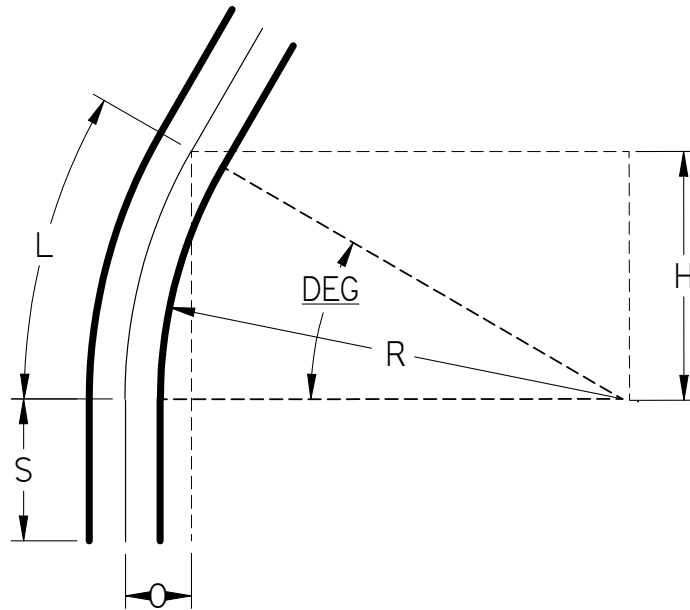

UL Listed 651  
 NEMA TC3  
 See NEC Article 352 for Usage

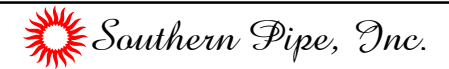

30° Elbows Plain End Schedule 40 48" Radius

UNLESS OTHERWISE SPECIFIED  
 DIMENSIONS ARE IN INCHES  
 ANGLES ±2.0°

	NAME	DATE
DRAWN	K. Mitchell	03/27/13
CHECKED		
ENG APPR		
FILE: 30 DEG SCH 40 48 RAD PE.dft		REV 10