

| Part Number | Size | Deg | R | O | H | S Min | B Min | L |
|-------------|--------|-----|------|-------|-------|-------|-------|--------|
| 41405 | 1/2" | 30° | 4 | 0.536 | 2 | 15 | 15 | 2.094 |
| 41408 | 3/4" | 30° | 4.5 | 0.603 | 2.25 | 15 | 15 | 2.356 |
| 41410 | 1" | 30° | 5.75 | 0.770 | 2.875 | 18.75 | 15 | 3.011 |
| 41412 | 1 1/4" | 30° | 7.25 | 0.971 | 3.625 | 2 | 2.0 | 3.796 |
| 41415 | 1 1/2" | 30° | 8.25 | 1.105 | 4.125 | 2 | 1.375 | 4.320 |
| 41420 | 2" | 30° | 9.25 | 1.239 | 4.625 | 2 | 1.75 | 4.843 |
| 41425 | 2 1/2" | 30° | 10.5 | 1.407 | 5.25 | 3 | 3.0 | 5.498 |
| 41430 | 3" | 30° | 13 | 1.742 | 6.5 | 3.125 | 2.875 | 6.807 |
| 41435 | 3 1/2" | 30° | 15 | 2.010 | 7.5 | 3.25 | 3.125 | 7.854 |
| 41440 | 4" | 30° | 16 | 2.144 | 8 | 3.375 | 3.375 | 8.378 |
| 41450 | 5" | 30° | 24 | 3.215 | 12 | 3.625 | 4 | 12.566 |
| 41460 | 6" | 30° | 30 | 4.019 | 15 | 3.75 | 5 | 15.708 |

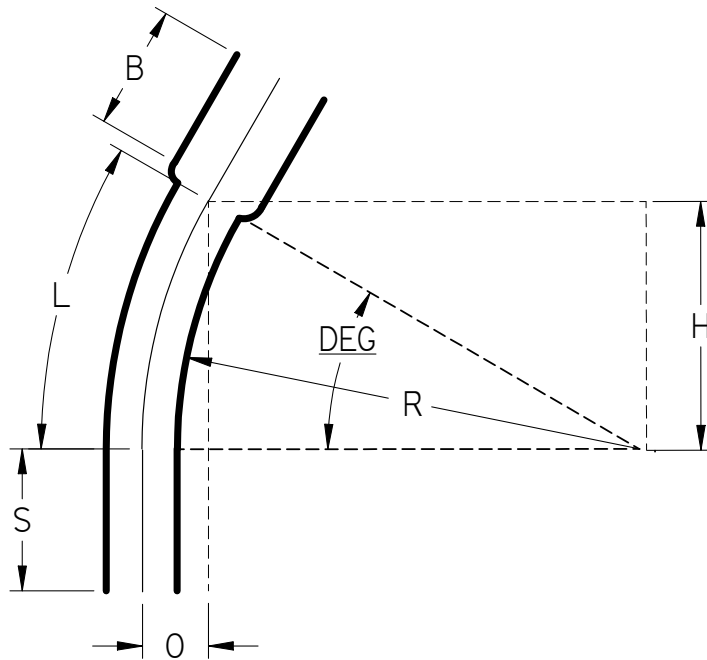

 Listed 651
 NEMA TC3
 See NEC Article 352 for Usage

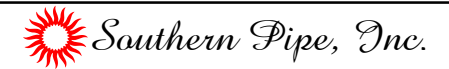

30° Elbows Belled End Schedule 40 Standard Radius

UNLESS OTHERWISE SPECIFIED
 DIMENSIONS ARE IN INCHES
 ANGLES ±2.0°

| | NAME | DATE |
|------------------------------------|-------------|----------|
| DRAWN | K. Mitchell | 03/27/13 |
| CHECKED | | |
| ENG APPR | | |
| FILE: 30 DEG SCH 40 STD RAD BE.dft | | REV 10 |