

Part Number	Size	Deg	R	O	H	S Min	L
53510	1"	30°	36	4.8125	18	1.875	18.875
53512	1 1/4"	30°	36	4.8125	18	2	18.875
53515	1 1/2"	30°	36	4.8125	18	2	18.875
43120	2"	30°	36	4.8125	18	2	18.875
53525	2 1/2"	30°	36	4.8125	18	3	18.875
53530	3"	30°	36	4.8125	18	3.125	18.875
53535	3 1/2"	30°	36	4.8125	18	3.25	18.875
53540	4"	30°	36	4.8125	18	3.375	18.875
53550	5"	30°	36	4.8125	18	3.625	18.875
53560	6"	30°	36	4.8125	18	3.75	18.875

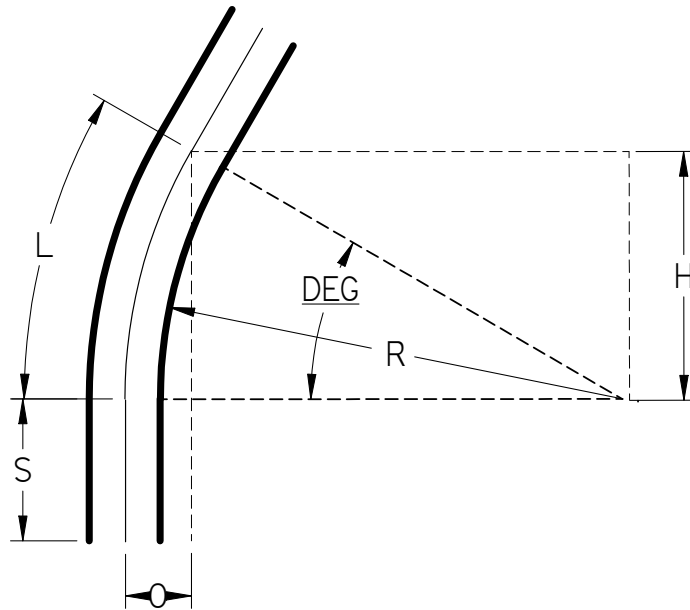

Ⓢ Listed 651  
 NEMA TC3  
 See NEC Article 352 for Usage



30° Elbows Plain End Schedule 80 36" Radius

UNLESS OTHERWISE SPECIFIED  
 DIMENSIONS ARE IN INCHES  
 ANGLES ±2.0°

	NAME	DATE
DRAWN	K. Mitchell	03/28/13
CHECKED		
ENG APPR		
FILE: 30 DEG SCH 80 36 RAD PE.dft		REV 10