

Part Number	Size	Deg	R	O	H	S Min	B Min	L
22710	1"	45°	24	17	7	1.875"	1.5	18.875
22712	1 1/4"	45°	24	17	7	2"	2	18.875
22715	1 1/2"	45°	24	17	7	2"	1.375	18.875
22820	2"	45°	24	17	7	2"	1.75	18.875
22825	2 1/2"	45°	24	17	7	3"	3	18.875
22830	3"	45°	24	17	7	3.125"	2.875	18.875
22835	3 1/2"	45°	24	17	7	3.25"	3.125	18.875
22840	4"	45°	24	17	7	3.375"	3.375	18.875

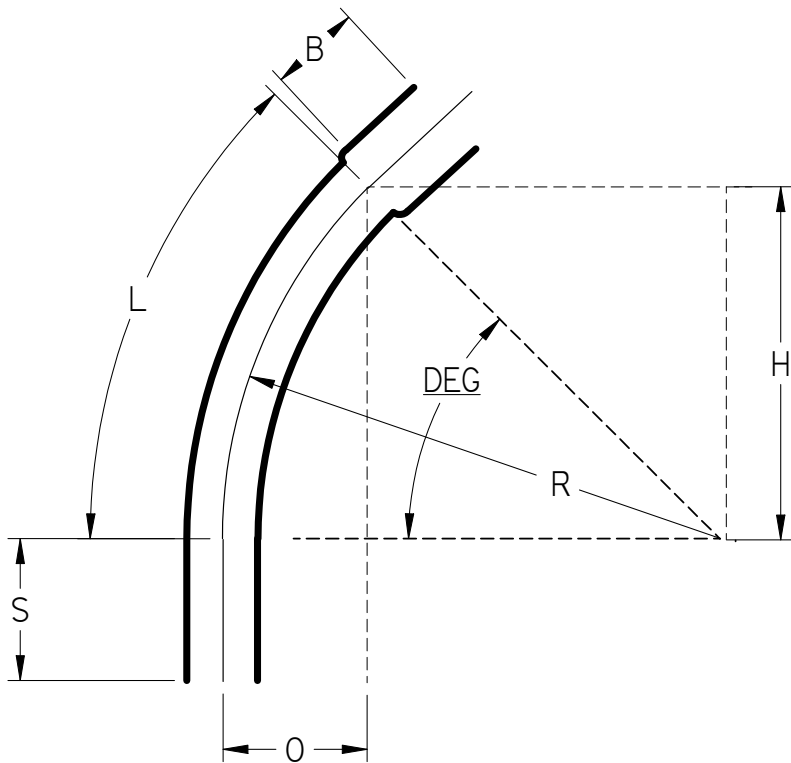

Ⓢ Listed 651
 NEMA TC3
 See NEC Article 352 for Usage



45° Elbows Belled End Schedule 40 24" Radius

UNLESS OTHERWISE SPECIFIED
 DIMENSIONS ARE IN INCHES
 ANGLES ±2.0°

	NAME	DATE
DRAWN	K. Mitchell	03/28/13
CHECKED		
ENG APPR		
FILE: 45 DEG SCH 40 24 RAD BE.dft		REV 10