

Part Number	Size	Deg	R	O	H	S Min	B Min	L
22910	1"	45°	36	10.5	25.4375	1.875"	1.5	28.25
22912	1 1/4"	45°	36	10.5	25.4375	2"	2	28.25
22915	1 1/2"	45°	36	10.5	25.4375	2"	1.375	28.25
23020	2"	45°	36	10.5	25.4375	2"	1.75	28.25
23025	2 1/2"	45°	36	10.5	25.4375	3"	3	28.25
23030	3"	45°	36	10.5	25.4375	3.125"	2.875	28.25
23035	3 1/2"	45°	36	10.5	25.4375	3.25"	3.125	28.25
23040	4"	45°	36	10.5	25.4375	3.375"	3.375	28.25
23050	5"	45°	36	10.5	25.4375	3.625"	4	28.25
23060	6"	45°	36	10.5	25.4375	3.75"	5	28.25

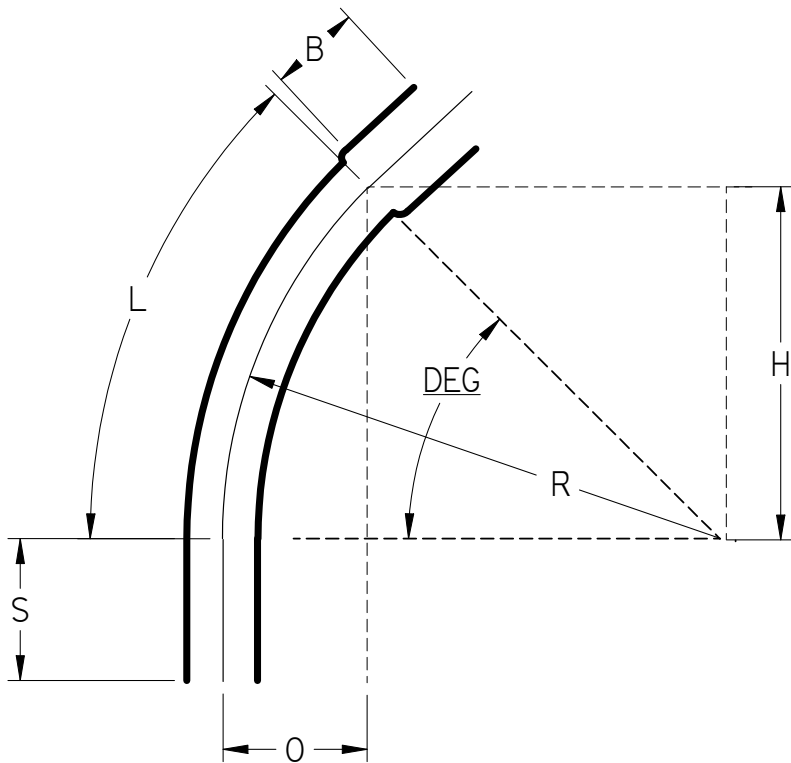

UL Listed 651
 NEMA TC3
 See NEC Article 352 for Usage

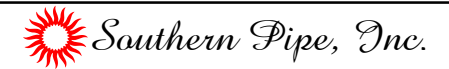

45° Elbows Belled End Schedule 40 36" Radius

UNLESS OTHERWISE SPECIFIED
 DIMENSIONS ARE IN INCHES
 ANGLES ±2.0°

	NAME	DATE
DRAWN	K. Mitchell	03/28/13
CHECKED		
ENG APPR		
FILE: 45 DEG SCH 40 36 RAD BE.dft		REV 10