

Part Number	Size	Deg	R	O	H	S Min	L
43112	1 1/4"	45°	48	14	34	2"	37.6875
43115	1 1/2"	45°	48	14	34	2"	37.6875
43120	2"	45°	48	14	34	2"	37.6875
43130	3"	45°	48	14	34	3.125"	37.6875
43140	4"	45°	48	14	34	3.375"	37.6875
43150	5"	45°	48	14	34	3.625"	37.6875
43160	6"	45°	48	14	34	3.75"	37.6875
40880*	8"	45°	48	14	34	6.625	37.6875

*8" Not UL Listed

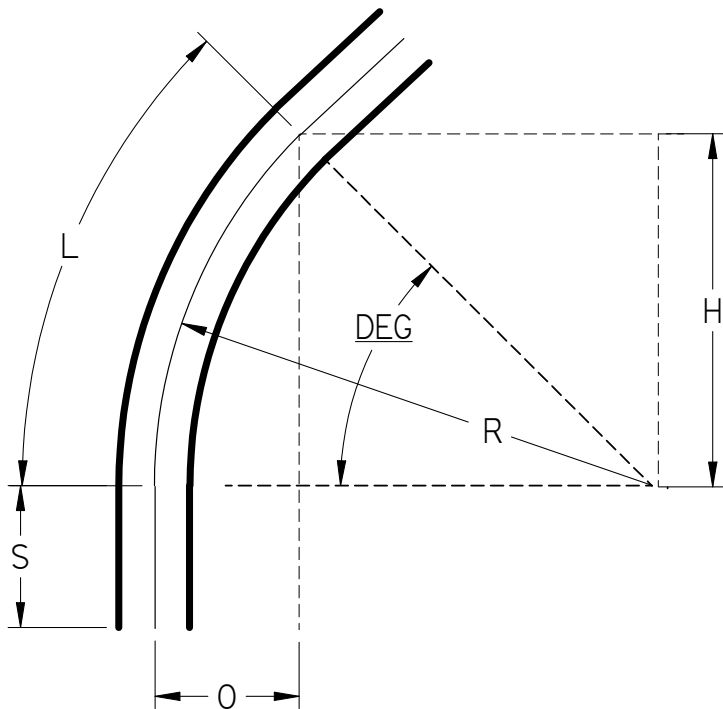

UL Listed 651
 NEMA TC3
 See NEC Article 352 for Usage

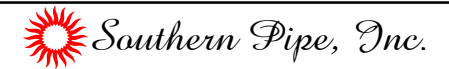

45° Elbows Plain End Schedule 40 48" Radius

UNLESS OTHERWISE SPECIFIED
 DIMENSIONS ARE IN INCHES
 ANGLES ±2.0°

	NAME	DATE
DRAWN	K. Mitchell	03/27/13
CHECKED		
ENG APPR		
FILE: 45 DEG SCH 40 48 RAD PE.dft		REV 10