

Part Number	Size	Deg	R	O	H	S Min	B Min	L
41305	1/2"	45°	4"	1.1875"	2.8125"	1.5"	1.5	3.142
41308	3/4"	45°	4.5"	1.3125"	3.1875"	1.5"	1.5	3.534
41310	1"	45°	5.75"	1.6875"	4.0625"	1.875"	1.5	4.516
41312	1 1/4"	45°	7.25"	2.125"	5.125"	2"	2	5.694
41315	1 1/2"	45°	8.25"	2.4375"	5.8125"	2"	1.375	6.480
41320	2"	45°	9.25"	2.8125"	6.75"	2"	1.75	7.265
41325	2 1/2"	45°	10.5"	3.0625"	7.4375"	3"	3	8.247
41330	3"	45°	13"	3.8125"	9.1875"	3.125"	2.875	10.21
41335	3 1/2"	45°	15"	4.375"	10.625"	3.25"	3.125	11.781
41340	4"	45°	16"	4.6875"	11.1875"	3.375"	3.375	12.566
41350	5"	45°	24"	7"	17"	3.625"	4	18.85
41360	6"	45°	30"	8.875"	21.25"	3.75"	5	23.562

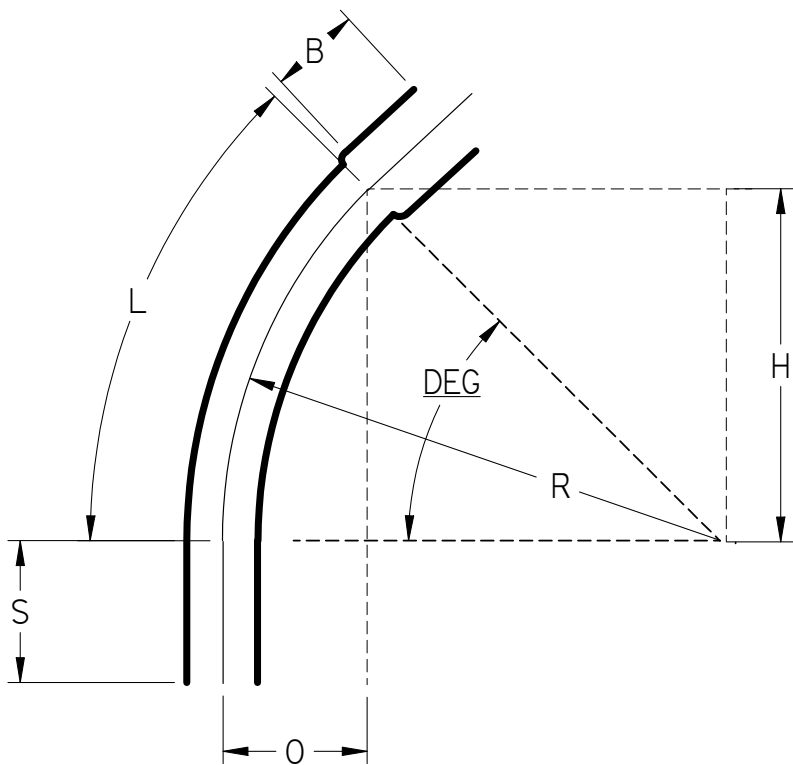

UL Listed 651
 NEMA TC3
 See NEC Article 352 for Usage

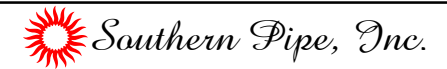

45° Elbows Belled End Schedule 40 Standard Radius

UNLESS OTHERWISE SPECIFIED
 DIMENSIONS ARE IN INCHES
 ANGLES ±2.0°

	NAME	DATE
DRAWN	K. Mitchell	03/27/13
CHECKED		
ENG APPR		
FILE: 45 DEG SCH 40 STD RAD BE.dft		REV 10