

Part Number	Size	Deg	R	O	H	S Min	B Min	L
41205	1/2"	90°	4"	4"	4"	1.5"	1.5	6.283
41208	3/4"	90°	4.5"	4.5"	4.5"	1.5"	1.5	7.069
41210	1"	90°	5.75"	5.75"	5.75"	1.875"	1.5	9.032
41212	1 1/4"	90°	7.25"	7.25"	7.25"	2"	2	11.388
41215	1 1/2"	90°	8.25"	8.25"	8.25"	2"	1.375	12.959
41220	2"	90°	9.25"	9.25"	9.25"	2"	1.75	14.53
41225	2 1/2"	90°	10.5"	10.5"	10.5"	3"	3.0	16.493
41230	3"	90°	13"	13"	13"	3.125"	2.875	20.43
41235	3 1/2"	90°	15"	15"	15"	3.25"	3.125	23.562
41240	4"	90°	16"	16"	16"	3.375"	3.375	25.133
41250	5"	90°	24"	24"	24"	3.625"	4.0	37.699
41260	6"	90°	30"	30"	30"	3.75"	5.0	47.124

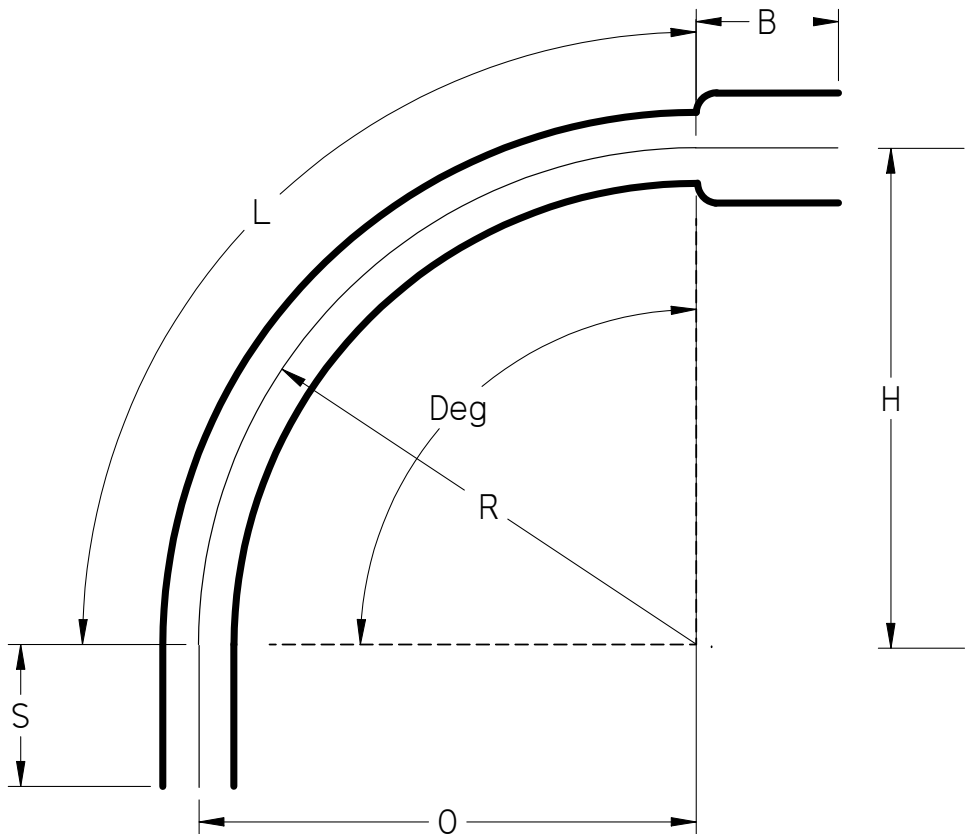

UL Listed 651
 NEMA TC3
 See NEC Article 352 for Usage

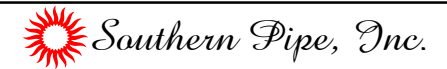

90° Elbows Belled End Schedule 40 Standard Radius

UNLESS OTHERWISE SPECIFIED
 DIMENSIONS ARE IN INCHES
 ANGLES ±2.0° BELLS -0.125", +0.5"

	NAME	DATE
DRAWN	K. Mitchell	03/27/13
CHECKED		
ENG APPR		
FILE:	90 DEG SCH 40 STD RAD BE.dft	
	REV	10