

Part Number	Size	Deg	R	O	H	S Min	B Min	L
52650	5"	90°	48	48	48	3.625"	4	75.375
52660	6"	90°	48	48	48	3.75"	5	75.375

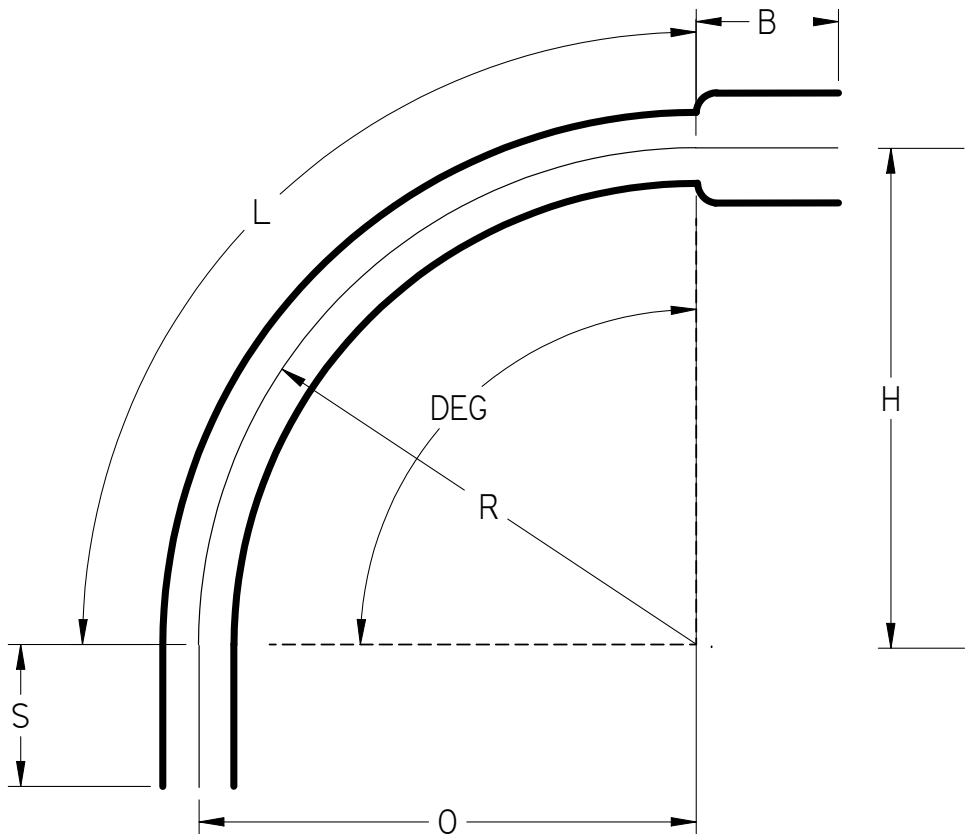

Ⓢ Listed 651  
 NEMA TC3  
 See NEC Article 352 for Usage

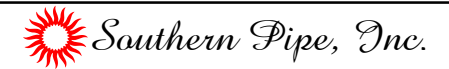

90° Elbows Belled End Schedule 40 48" Radius

UNLESS OTHERWISE SPECIFIED  
 DIMENSIONS ARE IN INCHES  
 ANGLES ±2.0°

	NAME	DATE
DRAWN	K. Mitchell	03/28/13
CHECKED		
ENG APPR		
FILE: 90 DEG SCH 80 48 RAD BE.dft	REV	10